



# HYDROVAC



Tornado F4 Hydrovac  
custom built for  
Eveready Industries

# TORNADO – The world's best Hydrovac!

Tornado has spent years developing the best dedicated hydrovac in the industry, and we are proud of our claim. Operators who choose Tornado never go back to any other manufacturer once they recognize the difference a Tornado hydrovac makes on their job site.

## TOPGUN Boom

Like a 3<sup>rd</sup> arm, Tornado's extendable boom delivers superior reach and mobility. Our unique head-mount design allows 342-degree rotation and a 26-foot stretch.

## Instant Setup

Without assembling hoses or dig tubes, operators love that they can immediately begin digging down to 23-feet before extensions are required. Time = money.

## Divided Tank

Water and debris have separate chambers, both epoxy coated and built for long life.

## Dual Silencers

Unique dual chamber system makes it the quietest truck in the industry – perfect for urban applications.

## Direct Driven PD Blower

Vacuum power! Our positive displacement Roots blowers have proven themselves superior to fans time and again. A full 27-inches Hg pull, direct-driven from the transfer case.

## Work Lights

These little details come standard on all Tornado hydrovacs.

## Dump Door

Large 48-inch hydraulic gate for fast, reliable unloading.

## Level Gauges

Accurate, reliable, and easy to see.

## Wireless Remote Controls

Freedom! All functions can be operated by wireless remote for one-man operation, backed-up with concise manual controls if needed.



## Tool Box Cabinets

Ample storage space for tools and equipment.

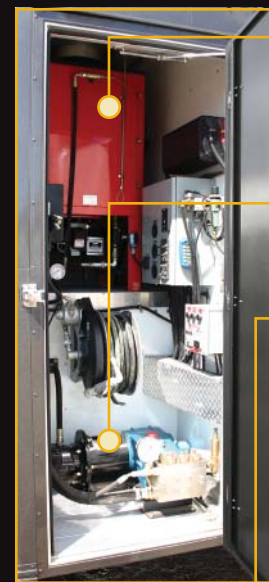

## Boiler

For frozen or hard-compacted soils, nothing beats hot water. Tornado's 740,000 btu/120V boiler offers independent diagnostic system and thermostat control.

## Water Pump

We use Cat Pumps for reliability and user-control. Outputs range from 14-60 GPM and 0-3,000 PSI.

## Van Body

All critical components are centralized and housed in an insulated, heated aluminum van body. Operators will especially appreciate this functional space located on both sides of the vehicle.

## Engineered from the ground up.

Excavation equipment is designed to move earth. We've analyzed and engineered every aspect of the hydrovac process to ensure your Tornado truck pulls the most dirt in the least amount of time with the easiest operation. *Superior productivity means greater operator profit.*



## Filter Housing

Tornado's unique 3-stage design delivers superior filtration. The cleanable cartridge is easily accessible and features an integrated vacuum break system.

## Axle Configurations

Anything from single 4x4's to tandem-steer tri-drives, Tornado offers custom versatility for unique operating terrain and road restrictions.



## Electrical Panel

Simple, clean and protected in an all-weather panel box. The blower, boiler and pump hours are all recorded individually.

## Built On Simplicity

Tornado hydrovacs are powerful, rugged and most important... simple. We understand that operators rely on user-friendly equipment to perform in the field with minimal downtime. That's how we designed them. All working components are easily accessible for visual inspection and routine maintenance. And most parts are readily available – not special order from the manufacturer.



## Integrated Water Tank/Cyclone

Less space, lower noise output and no freeze-ups. We only thought it made sense to do it this way.

## Hydraulic Mud Sweep

Simply better! Our patented system means no tank hoisting and permanent vacuum piping. The sweep pushes with 50,000 lbs of force to move any size debris.

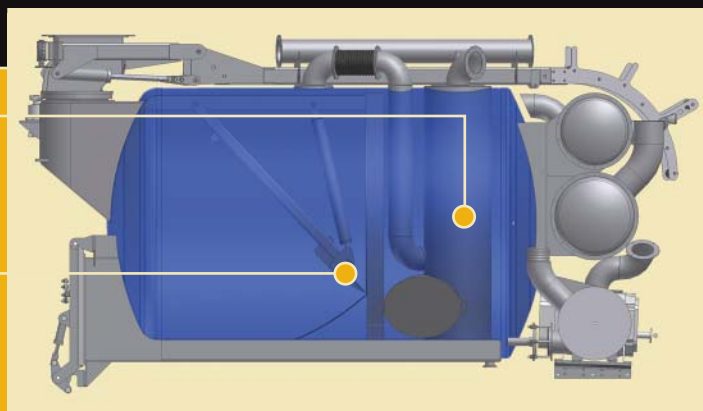

## Dig Tube Rack

Tidy, convenient and quick access.

# TORNADO

## Hydrovac Model Specifications



### Tornado F1

### Tornado F2

### Tornado F3

### Tornado F4

Debris Capacity	4.0 cu. yd	7.0 cu. yd	13.0 cu. yd	13.0 cu. yd
Water Capacity	550 US GAL	1000 US GAL	1627 US GAL	2366 US GAL
Standard Blower	2367 cfm / 27" hg	2367-3658 cfm / 27" hg	3658-5750 cfm / 27" hg	3658-5750 cfm / 27" hg
Standard Water Pump	Cat tri-plex water pumps • 14-60 GPM • 0-3000 PSI			
Standard Boiler	740,000 btu / 120V Hotsy with full diagnostics			
Filtration	3 Stage			
Boom	6" TopGun	6" TopGun	8" TopGun	8" TopGun
Offloading	33" Powersweep	33" Powersweep	48" Powersweep	48" Powersweep
Debris Door	33" x 33"	33" x 33"	48" x 36"	48" x 36"
Controls	Wireless / Manual Backup			
Cabinetry	Tornado Van Body • Two frame-mounted tool boxes • Storage			
Lighting	Work lights • Beacons • High mount signal lights • Traffic boards <small>(optional)</small>			
Service Center	Boiler hour meter • Pump hour meter • Blower hour meter			
Winterize Features	Glycol Pot • 12V Water Recirculation <small>(optional)</small>			
Standard Accessories	Dig tubes and rack • Extensions • Wand Heads			
Recommended Application	Urban Work	Urban Work	Heavy Industry	Heavy Industry



***"I have personally operated nearly every hydrovac available on the market today — without question, the Tornado truck will out produce any of them. They are the most cost-effective, productive, and ultimate "money-making" hydrovac in the industry."***

**James Broderick**  
General Manager, Rockies Construction LLC (Colorado)



## TORNADO Technologies Inc.

Box 1799, Stettler, Alberta, Canada T0C 2L0 • **Courier:** 4102 - 44 Avenue  
**Toll Free:** 877-340-8141 • **Tel:** 403-742-6121 • **Fax:** 403-742-1905  
 info@tornadotech.com • [www.tornadotrucks.com](http://www.tornadotrucks.com)